

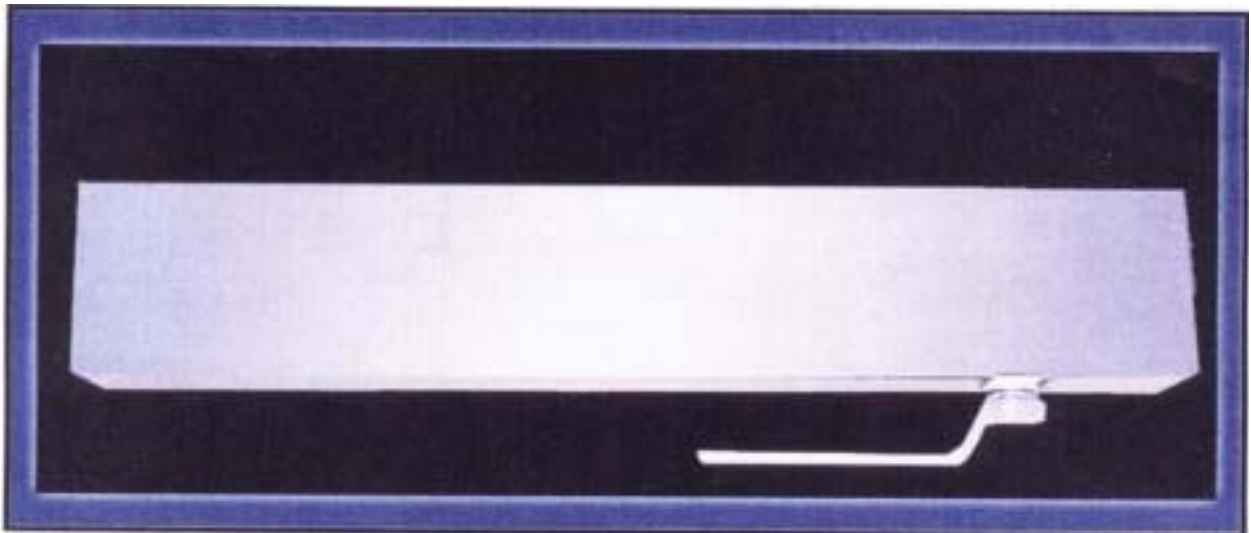

MODEL 2000 OPERATOR INSTALLATION MANUAL

AUTOMATED ENTRANCE, INC. was founded on and continually strives to produce the best automatic door operator possible. We thank you for selecting our product for this entrance. Please read these directions completely. Understand that they are written for a typical installation and may need to be altered for each installation. This operator will perform for years once installed correctly. Be sure to adhere to all local codes and ANSI A156.19 “Standards for power assist and low energy Power operated Doors”.



AUTOMATED ENTRANCE, INC.
148 E. Garfield Suite B
Coldwater, mi 49036
Phone: (517) 279-7533 Fax: (517) 279-0125
automatedentrance@aol.com

Website: <http://automatedentrance.com/>

Table of Contents

Introduction.....	1
Table of Contents.....	2
Tools Required.....	3
General Conditions	3
Receiving Inspection.....	4
Installation.....	5
110 V.A.C. Connections	6
Arm Installation	7
Activation.....	8
Control Features.....	9
Control Adjustments	10
Concealed unit	13
Decals.....	17
Automatic Wiring Diagram	18
Knowing Act Diagram.....	19

TOOLS REQUIRED

(1) Knife (1) Level (1) Tape Measure (1) #2 Phillips (1) #3 Phillips Bit
(1) 3/16" Drill Bit (1) 1/2" Drill Bit (1) 3/8" Drill Bit (1) 3/8" Drill
(1) Box 3/16 x 1 1/4" Tapcons (1) Wire stripper/Crimper
(1) Hacksaw (1) Countersink (1) set of Allen Wrenches

GENERAL CONDITIONS

The Model 2000 is designed for residential, commercial, and industrial use. If it is to be retrofitted on to an existing door and frame, it is important that the door is in good condition and swings without restriction. It is also important that the header is sturdy and unit is fastened securely using the appropriate fasteners.

All electric wiring must comply with the National Electrical Code

This is a low energy operator and must comply with ANSI A156.19. It is not a solution to wind or stack air conditions. If these conditions exist, please call factory for advice and possible solutions.

Be aware that the door should:

1. Open to provide at least 32 inches of clear opening.
2. Have 5' x 5' of flat floor on both sides of door.
3. Be protected at the bottom rail, 7 1/2" up.
4. Not have a threshold higher than 1/2 inch.

RECEIVING INSPECTION

Inspect package for possible shipping damages, Carefully cut straps and taape and unfold cardboard box. Packed in this box you will typically find (1) arm assembly, (1) set door decals, and any wiring diagrams pertinent to your operator.

Remove items and place them carefully aside so they will not be damaged or lost. Using a #2 Phillips, remove the four (4) coverf screws. Remove cover. Remove packing and inpsct for items wrapped in it. You should inspect all items before continuing.

CONTACT FACTORY ON DAMAGES AND MISSING EQUIPMENT



INSTALLATION PREPARATION

The hanger bracket assembly is unique to the Automated Entrance low energy operators. It allows you to install the operator by one person, quickly and efficiently.

Locate Phillips screws inside at the tip corners. Remove these and separate the header from the hanger plate. On the hanger plate, measure in 7/8" and 11" from both ends. Mark and drill a 3/16" hole and counter sink on the bottom Webb.



INSTALLING

The Hanger plate should be located 1/8" from hinge side at outside jamb. Level and flush with bottom of header. Vise clamp to header and drill through holes a 3/16" hole. Fasten with Tapcons using drill and #3 Phillips Bit.



HEADER LOCATION FOR PULL OR DUAL UNITS

The bottom of the header should be approximately 2 1/8" above the top of the door. The goal here is to be able to pass the door under the main shaft of the unit. Depending on the pivot (i.e., offset) of the door, the location from pivot end of unit differs. Your goal is for the elbow of the arm to have clearance on the backside of the door.

Lift the operator and lower onto the webs of the hanger bracket. Be sure both top and bottom are engaged. Once they are seated gently pull down until unit is completely flush and screws can be replaced in top corners.



110 VAC CONNECTIONS

Have a licensed electrician bring 110 to the swinger in accordance with all local and state electrical codes. Be sure the 110 power supply is off before proceeding. The 110 power line must be run through the knockout hole(s) in the end of the unit case. A handi-box and plug receptacle is located inside case on the latch side. You should inspect all wiring at this time before turning on the power.



ARM INSTALLATION

Start with round adjustment pots for “Accel”, “Daccel”, “Speed”, “Check”, and “Hold” set at 3:00 (3 o’clock).

Push down Test Button located below the 12-wire connector, (cn2). The operator will activate and the splined output shaft will rotate 340° (degrees). The yellow LED light labeled “HOLD” will illuminate. During this period the operator should remain in the full open position.

If the operator reverses while yellow LED light is on, turn the dial labeled “HOLD” clockwise until the operator turning. Re-activate the operator and check that it stays open until yellow LED light goes out.



Re-activate operator to full open. Attach the power arm onto the splined shaft so that it is pointed at a 50°-60° (degrees) angle through the door opening. Tighten screw on arm to secure to shaft.

Allow operator to close and then re-activate with brown test button. With the jumper on the “Push-toGo” you will be able to re-activate by pushing on the arm and operator will activate on its own.

Be sure operator is at full open by forcing arm to rotate past its stop position. If you can rotate operator beyond this position, turn the dial labeled “Check” clockwise until operator gets to full open.



The door foot will be located 16” center from the hinge side of the door panel and level when rod is inserted in sleeve attached to power arm.



With the operator at full open, hold the steel rod next to the rod connector at the end of the arm. Mark the steel rod to indicate where to cut the rod so it will fit into the rod connector until desired opening is achieved. Tighten setscrews to secure rod.

CONTROL FEATURES

TSTOP L-OUT OPEN TIME HOLD FORCE DACCL ACCEL

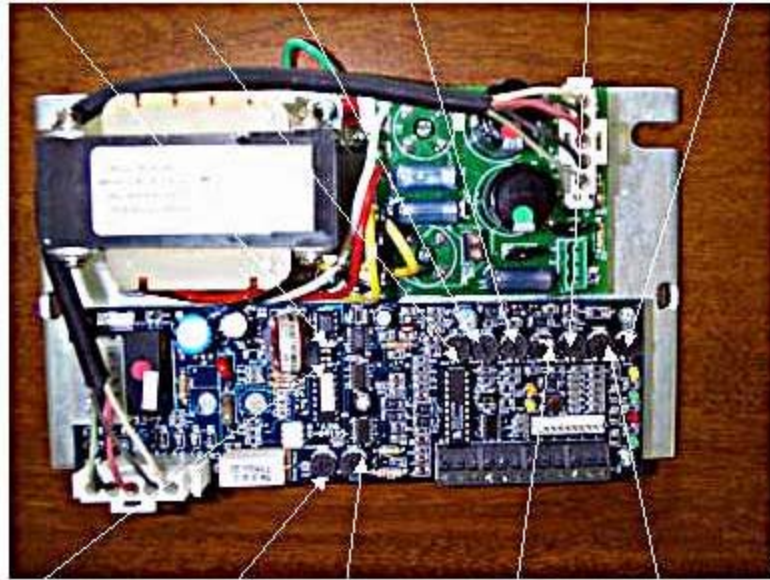

PUSH-N-GO OBSTRUCTION LIMIT BACK-CHECK OPEN SPEED

This is a handi-cap operator and must be adjusted to ANSI 156.19 and ADA guidelines. Briefly ANSI 156.19 requires that:

1. A door shall not open to 80 degrees any faster than 3 seconds.
2. A doors shall not close from 90 degrees to 10 degrees any faster than 3 seconds.
3. A dooe shall not remain in the open position any less than 5 seconds.
4. A power assist handi-cap door shall have approved handicapped door decals.

CONTROL ADJUSTMENTS

Now you need to adjust open “Speed” and time “Delay” to meet ADA requirements. To do this activate operator and count the number of seconds it takes from activation to the start to back “Check”. This time cannot exceed 3.5 seconds. The time is adjusted by the dials labeled “Accel”, “Daccel”, and “Speed”.

ACCEL – This dial adjusts how fast the door ramps up to the “Speed” setting of the control. A slow Accel setting reduces the jerking and increases the longevity of all the mechanical parts.

DACCEL – This dial adjusts how fast the door swing slows down to “Check” speed. Adjust this dial so there is no visually abrupt change at 80° open.

SPEED – This dial adjusts the maximum speed the door will travel at between “Accel” and “Daccel”.



CAM

CHECK - This dial adjusts the speed of the door travel after “Daccel” to final full open. Adjust this so the door is traveling as slow as possible to final open. This will reduce damage to mechanical parts of operator. “Check” speed is activated when the CAM, (on top of gearbox), allows the three (3) wire micro-switch to “drop” into the cutout on the cam. The CAM is adjustable through the top of the header case by removing the plug and using a 1/8” allen wrench. Do not over tighten!

HOLD – This dial adjusts the amount of force the motor applies to the door to hold it open. The control drops to this power level 7 to 9 seconds after activation and maintains it until “Delay” time expires. The yellow LED is illuminated during the “Hold” time.

Adjust dial counter-clockwise until the door starts to creep shut. Then increase the dial until the door begins to stall. This must be done while the yellow LED is lit.

HOLD setting also determines the value of the obstruction feature. A high “HOLD” setting will cause the door to continue to creep open after the door hits an obstruction during the opening cycle.

DELAY – This dial adjusts the amount of time the door will remain at full open, from 0 to 28 seconds.

Make your adjustments so the door swing starts slow and increases speed. Then the door slows to full open in five (5) seconds or more. The door must remain open for five (5) seconds or more.

CLOSE SPEED CONTROL – Located above the motor is the “Close Speed” Adjustment module. Set the dial so the closing time is five (5) seconds or more.

LIMIT – This dial adjusts the amount of force the door can generate during the opening cycle. Rotate the dial clockwise until the door applies less than 15 lbs. Of pressure using a force pressure gage.

OBST – Obstruction. Place an obstruction in the opening path of the door and rotate the dial clockwise until the door stalls and the yellow LED lights up.

L-OUT – Lock-out. This dial adjusts the lock-out period of on the swing side presence detector. The red LED labeled “Lock-out” indicates the time of the lock-out. Turn this dial clockwise to increase the length of the “Lock-out” time.

Adjust this dial so the red LED remains illuminated for the entire closing cycle. This function interrupts the safety signal from the safety sensor while the door closes. This allows re-activation from the approach side of the door during the closing cycle.

JUMPERS

There are three (3) jumpers for you to consider.

JB1 – “PUSH-N-GO” is set to ON at the factory. This function activates the operator when the door is manually pushed open. When the door is manually pushed open the hold open time is one third (1/3) of an actuator-activated time. To deactivate “Push-N-Go”, remove the jumper.

JB2 - “TSTOP” is set to ON at the factory. This is a safety feature. When the door meets an obstruction during the closing cycle, the control will reactivate. This function will automatically de-activate when the two (2) wire micro-switch drops into the cutout section of the CAM, “Latch-check” on top of the gearbox. Due to the preload and over-rotation of the gearbox, the unit will reactivate until door is connected to the unit. To deactivate this feature, remove the jumper.

JB3 – “Lock-Delay” is set to OFF at the factory. Connecting this jumper will provide a .25 (1/4) second delay after activation to allow for a strike to dis-engage.

TRACK POSITIONING FOR PULL UNITS

After header is secured, activate unit and open the door to 90 degrees. Put the arm on so wlbow is on backside of door. Take track and place it up to plastic slide block. Center in slide and mark holes for bolts. This gearbox is factory built to a 90-degree opening. To reduce or increase opening call factory.

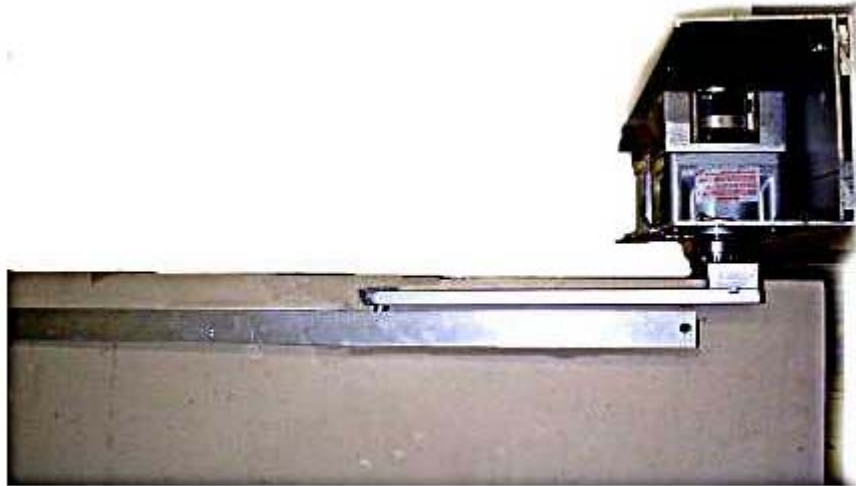

CONCEALED UNIT

This system is designed for end load door panels and pivots. Prep jamb according to template below. Raise header and fasten thru end plate.

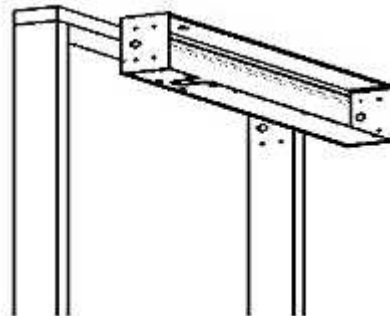
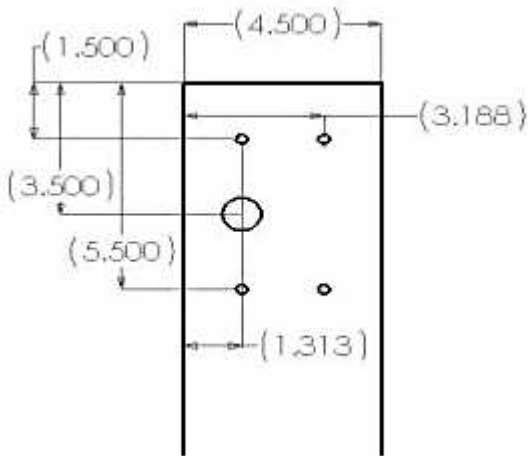

We have provided ¼ - 20 bolts to fasten header to frame.

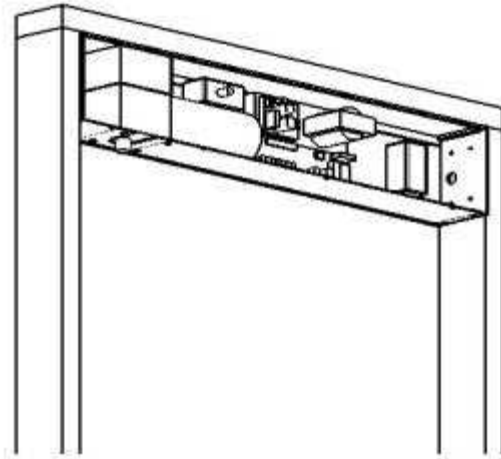

The gearbox and arm have been designed for a full open position at 90 degrees open. Activate the control and allow pivot to rotate until it comes to a full stop. You may now load the arm onto the spindle. You may put a jumper on #2 and #3 of the 12 wire terminal strip on control to hold activation while you do this.

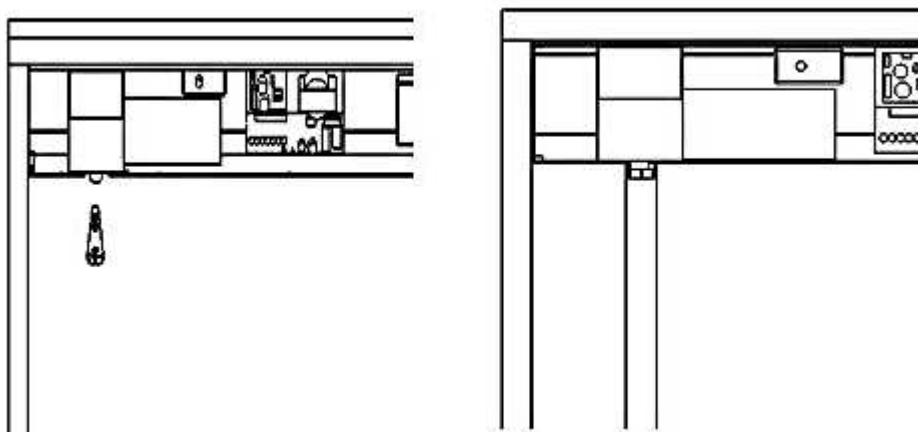

Set your door on your bottom pivot and move top of door in until level. Position door at 90 degrees and fasten arm to top of door. The arm design will allow a few degrees of movement to achieve the opening you desire.

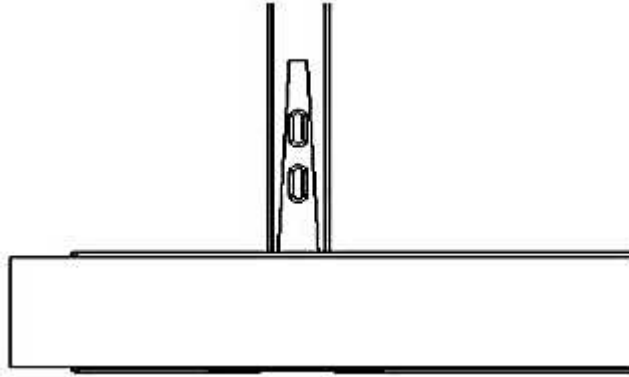

Before drilling holes make final opening adjustments.

LOW VOLTAGE ACTIVATION CONNECTIONS

Along with your unit you received on/off toggle and any ancillary components you have ordered, pre-wired into the control. The toggle can be located in end of header or on jamb using a 1/2" drill bit. Keep in mind accessibility to use or misuse.

THIS UNIT IS TO BE USED WITH APPROVED SWITCHES AND OR SENSORS.

Typically you will use a wall mounted, hardwired push button. You must provide wire from the button to the unit. You can run the wires through the knockouts on either end of unit case. Connect one of each button wires to the black wire in gray cable and one of each to the red wires connected to #2 and #3 on 12 wire terminal strip. Refer to your diagram included in unit.

Be sure all wiring meets all state and local codes.

Another popular style of button has battery-operated transmitters. When ordered, you will receive a receiver pre-wire to the control. Be sure to connect battery in buttons to "COM" and "N.O.". Each button and each receiver have code settings that must match. Refer to button paper work for instructions on changing codes.

These must be accessible to persons in wheel chairs with a clear view of swinging door and out of the path of the door.

DECAL APPLICATION

We have supplied you with the correct door labels in your swinger package. One decal is round with the international Handicapped symbol, blue with white background. The second decal has “CAUTION AUTOMATIC DOOR” in black on yellow background.



Both decals are double sided. They are to be applied to the swing door at 58 inches + / - 5 inches from finish floor in clear view.

FINAL INSPECTION

Before leaving site, test all activation devices and time your door. To reduce callbacks, instruct owner on the legal operation of door, how to turn on and off, “PUSH-N-GO” function, and warranty considerations.

As an installer, you may have a suggestion for improvements to swinger or our manual. Please feel free to call or fax us. Your expert input will help us provide you with the best operator possible.

Thank you.